

Review based Paper on Power Entity with Unified Power Flow System

Md. Shahid Iqbal¹, Varsha Mehar²

¹Electrical Department, RKDF University, Bhopal, M.P, India

²Electrical Department, RKDF University, Bhopal, M.P, India

¹ mshahid9281@gmail.com, ² varshamehar86@gmail.com

* Corresponding Author: Md. Shahid Iqbal

Manuscript Received:

Manuscript Accepted:

Abstract: During the past 2 decades, increase in electrical energy clamor has presented higher obligation by the power industry. More power plants, base station and transmission lines need to be buildup. so that the most frequently used devices in the day today power entity grid are perfunctorily switched circuit breakers. The long switching periods are separate operation makes them hard to handle the frequently changed load fluently and damp out the ephemeral oscillations quickly. In order to counterbalance these drawbacks, large operational perimeter and redundancies are well-kept to protect the entity from dynamically allomerosum and recovers from faults. This not only increases the cost and lowers the efficiency, but also increases the faults. This not only mounts the cost and inclines the figure of merit, but also mount the complexity of the entity and increase the difficulty of transaction and control. Severe black outs coincide recently in power network worldwide and these have excavate that stodgy transmissions are unable to manage obligation of complicated interconnections and inconsistent power flow. Now a day with the ever increasing demand of electrical power, absence of long term planning and need to provide open access to generating companies and companies and consumers it becomes more ambitious to maintain the protection, reliability, continuity, and oriental's of power supply. Further the incorporated power entity is strained by transient firmness; voltage firmness etc. due to sudden retardation in load, sudden eternalize in generator output, transmission line shift short circuits, transmission lines is often subjected to traveler oscillations. So in order to secure the entity it is necessary to modernize the existing entity rather than to have new transmission line and power station for economical and environmental reasons. So the need of recent power flow comptroller capable of mounting transmission capacity and comptroller power flows within limit will certainly increase. Ideally there is a obligation of a comptroller which should be surefooted to manage the voltage, active and reactive power flow to allow the secure burden closer to the thermal margine of transmission lines. Because of increasing rate of growth of modern industries as well as populations it is not possible to generate that much amount of power due to limited.

Keywords: Complexity, STATCOM, SVC and Entity

I. Introduction

For selecting the project topic we had studied various IEEE papers and journals and collected the information regarding the various difficulties occurring in the power entity. Further we focused on the imbalance that is taking place due to occurrence of the fault and tried to find out the solution to solve these difficulties.

II. LITERATURE REVIEW

The balance of an internetwork power entity of its capability to return to normal or stable working condition after getting been subjected to some form of difficulties. Conversely, disturbance means a condition showing machine lost synchronism or falling away of step.

Accordingly power entity balance difficulties are differentiate into 3 basic type's steady state, dynamic and transient. The study of constant state balance is normally concerned with the find out of the higher cap of machine burden before getting out of synchronism, provided the burden is increased gradually.

Dynamic imbalance is more probable than steady state imbalance. Small disturbances are continually occurring in a power entity which excites the entity into the state of natural oscillation. This kind of imbalance behavior constitutes a serious problem to entity security and creates very problematic managing conditions.

Following a sudden to disturbance on a power entity rotor speeds, rotor angular distinction and power flow undergo quick changes that cause the machines to fall out of step. This type of imbalance is known as transient imbalance [1].

- The important parameters of FACTS regulator and their capability to make better entity balance is the main concern for effective & economic working of the power entity. The location and response signals used for FACTS- based imbrue regulator were discussed. The organization problem between different manage schemes was also advised. Performance compare of different between FACTS regulator has been analyzed.

The likely future direction of FACTS skill was discussed. A brief review of FACTS application to optimal power flow and deregulated electricity market has been presented [2].

- Voltage profile improvement and balance enhancement of power entity using UPFC is presented in the paper. Simulink models of five bus test entity and UPFC are developed. The test entity was analyzed with and without incorporating UPFC. Thus, it was concluded that balance of power entity and voltage profiles improves with incorporation of UPFC [3].
- When an LLG fault is considered under different cases i.e. sending end, receiving end and intermediate of conduction line it is observed that UPFC improve the entity act by the way of maintain voltage, power and current under fault condition [4].
- Real power flow manage by reactive voltage injection.
- oblique reactive power stream manage by manage of electrical energy at the 2 ports of the UPFC. The regulator are intended independently and use locally accessible measurements. The simulation outcome for a case study shows that this is a feasible manage plan. By modulate the active power it is likely to bring a vast improvement in momentary balance and damping [5].

III. STATCOM

III-A Introduction

A static contemporaneous give the waste power (STATCOM) is a regulating apparatus used on A.C electricity transmission mesh. It is setup on a power electronics voltage supply convertor and can do something as either a supply or sink of imprudent AC power to an electricity mesh. Usually a STACOM is constructed to sustain electricity mesh that has a reduced power factor and over and over again reduced voltage regulation. There are on the other hand, other use, the most general use is for voltage balance. The document is depends on systematic and simulation examination, and conclusion can be utilized as power industry guidelines. In this document, we give information the principle formation of STATCOM and the impact of these tools on midpoint voltage guideline.

Static Compensator (STATCOM) is a 2 generation's shunt coupled FACTS devices depends on a voltage basis converter (VSC) by means of GTOs. STATCOM balance the bus voltage by supply the obligatory reactive power yet at low bus voltages and improves the power sway damping. STATCOM has a sum of recompense over the traditional Static Var Compensation (SVC).

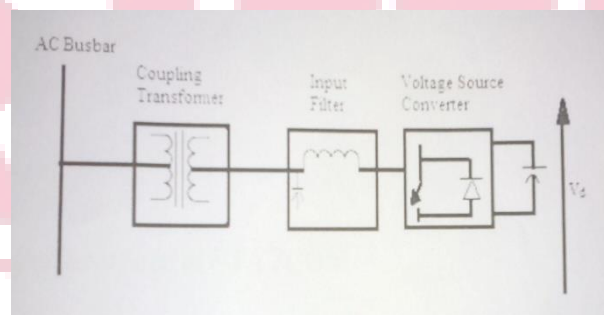

Figure.1 Circuit with STATCOM

STATCOMs are typically applied in long distance transmission entities, power substations and heavy industries where voltage balance is the primary concern. In addition, static contemporaneous compensators are installed in select points in the power entity to perform the following:

Voltage support and control Voltage fluctuation and flicker mitigation Unsymmetrical load balancing Power factor correction Active harmonics cancellation Improve transient steadiness of the control entity Design.

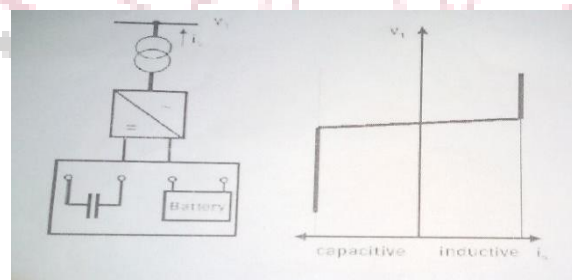

Figure. 2 Phasor diagram of STATCOM

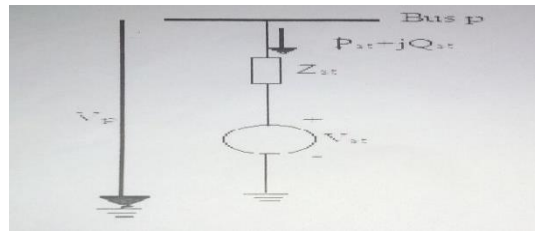

Figure.3 Equivalent circuit of a STATCOM

III-B BASIC managing PRINCIPLE

- Here the controllable reactive control is generated without the utilization of AC capacitors or reactors.
- Working of STATCOM is analogous to contemporaneous machine used as contemporaneous condenser by controlling the excitation of which in twirl controllers the amplitude of induce emf E w.r.t. to voltage V the reactive power stream can be restricted.
- If $E > V$ machine is over excited and leading current close in AC entity and machine is see as capacitor.
- If $E < V$ machine is under thrilled and lagging current secure in AC entity and machine is seen as inductor.
- In a STATCOM from a DC key in voltage source provided by capacitor the voltage source convertor make a set of convenient 3 phase O/P voltages with Freq of AC entity.

By varying amplitude of output produced by convertor the imprudent power swap can be restricted. In real transmission appliance sum of elementary convertors like three phase two level six pulse or twelve pulse with pulse width modulation schemes are used. If only reactive power is to be controlled the dimension of DC capacitor is relatively small, if the convertor is used to manage both active as sound as reactive power a DC capacitor with energy storage of significant capacity required.

III-C BASIC MANAGE SCHEME

The gating commands for the turn off devices the convertor are generate by the internal convertor manage as per to the demand of reactive and active power required major purpose of this scheme is to operate the convertor power switch so as to make a contemporaneous output waveform with demanded enormity and phase angle at same Freq of AC entity. For external entity, the input I_p reference and I_q reference are provided for the calculation of enormity and phase angle of the required output voltage.

Depending on the enormity of V_0 and a coordinated timing waveform gating pattern is generated which determines the on-off periods of each switch of convertor.

IV. CASE STUDY

Our project mainly deals with the balance of power which is achieved by using the FACTS skill. We have observed the various effects of FACTS devices on the entity balance due to the occurrence of any faulty condition by doing simulation on MATLAB.

Basically, we designed a power entity having two power plants generating 500 MW and 1000 MW and connected by a double circuit line. In our project we are mainly focusing on the rotor angle deviation due to imbalance and to create this imbalance, we inserted a LLLG fault in the transmission line results have been observed for the rotor angle deviation δ_0 and the peak overshoot of the oscillation and its settling time are noted.

A UPFC be used to handle the power flow in a 500 kV /230 kV spread entity. The entity, coupled in a loop design, consists fundamentally of five buses (B1 to B5) organized through transmission lines (L1, L2, L3) and two 500 kV/230 kV Xmer banks Tr1 and Tr2. 2 power plants situated on the 230-kV entity create a total of 1500 MW which is transmitted to a 500-kV 15000-MVA the same and to a 200-MW load coupled at bus B3. The plant model includes a rate regulator, an excitation entity as well as a power entity preservative (PSS). In normal process, most of the 1200-MW generation capability of power plant #2 is export to the 500-kV the same through three 400-MVA Xmer connected among buses B4 and B5. We are permit for a eventuality case somewhere only two Xmer out of three are accessible (Tr2= 2*400 MVA = 800 MVA).

Using the stack flow choice of the powgui obstruct, the model has been started with plants #1 and #2 generating in that order 500 MW and 1000 MW and the UPFC out of service (Bypass breaker closed). The ensuing power stream obtains at buses B1 to B5 is indicate by red sum on the circuit diagram. The load stream shows that the majority of the power generate by plant #2 is transmit through the 800-MVA Xmer bank (899 MW out of 1000 MW), the rest (101 MW), circulating in the ring. Xmer Tr2 is therefore filled to capacity by 99 MVA. The example illustrates how the UPFC can reduce this power jamming.

The UPFC to be found at the precise last part of line L2 is used to hang on the active as well as reactive energy by the side of the 500-kV bus B3, as fine as the electrical clout by the side of bus B_UPFC. It made of a phasor sculpt of two 100-MVA, IGBT-based, changer (one connected in shunt and one connected in string and both unified through a DC bus on the DC part and to the AC power entity, all the way through coupling reactors and transformers). ratings of the UPFC power apparatus are given in the dialog box. The string changer can inject a utmost of 10% of titular line-to-ground voltage (28.87 kV) in string with line L2. The blue numbers on the diagram show the power stream with the UPFC in overhaul and calculating the B3 active and reactive powers in that order at 687 MW and -27 Mvar. Next, the UPFC is replaced by a different FACTS device STACOM with evaluation same as sooner than various reproduction results are obtaining by means of STACOM and afterward is synchronized with PSS.

STATCOM has a rating of +/- 100MVA. This STATCOM is a phasor sculpt of a typical 3-level PWM STATCOM. If you unwrap the STATCOM dialog container and choice "Display Power data", you resolve see that our sculpt represent a STATCOM have a DC link titular voltage of 40 kV by means of an the identical capacitance of 375 uF. Scheduled the AC side, its entire the identical impedance is 0.22 pu on 100 MVA. This impedance represents the Xmer leakage reactance and the phase reactor of the IGBT Bridge of an authentic PWM STATCOM. It is pragmatic that the settle instance of oscillation peak overshoot is pretty less. Here is a mark able change in the result comparing to the previous result.

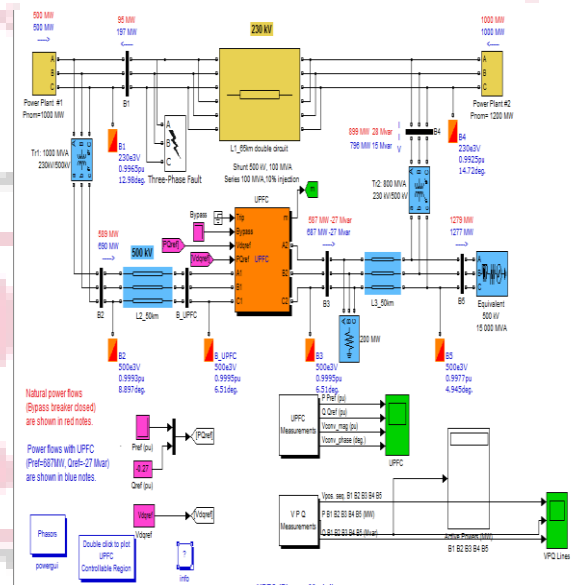

Figure.4 Power entity Model with UPFC

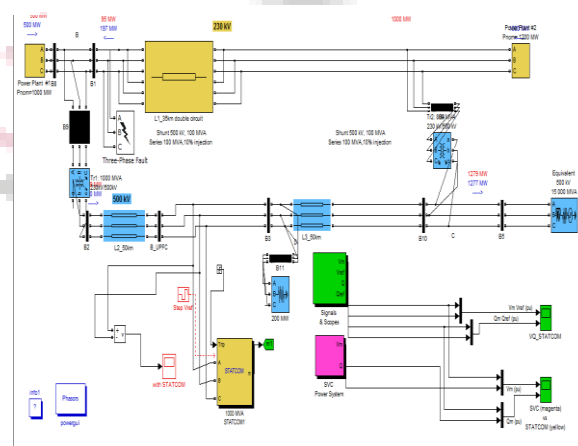

Figure.5 Power entity Model for STATCOM

References

- [1] Mohammadali Rostami, Saeed Lotfifard, "Scalable Coordinated Manage of Energy Storage entities for Enhancing Power entity Angle Balance", Sustainable Energy IEEE Transactions on, vol. 9, pp. 763-770, 2018, ISSN 1949-3029.
- [2] Shah Arifur Rahman, A C Mahendra, Rajiv K. Varma, Wayne H. Litzenberger, "Bibliography of FACTS 2012–2013: IEEE working group report", PES General Meeting | Conference & Exposition 2014 IEEE, pp. 1-35, 2014.
- [3] Fan Li; Ying Chen; Rui Xie; Chen Shen; Lu Zhang; Boyu Qin, "Optimal Operation Planning for Orchestrating Multiple Pulsed Loads with Transient Balance Constraints in Isolated Power entities," IEEE Access Year: 2018, Volume: PP, Issue: 99.
- [4] Hamid Reza Moradi; Heydar Chamandoust, "Impact of multi-output regulator to consider wide area measurement and manage entity on the power entity balance," 2017 IEEE 4th International Conference on Knowledge-Based Engineering and Innovation (KBEI)Year: 2017 Pages: 0280 – 0288.
- [5] Xiongfei Wang; Frede Blaabjerg, "Harmonic Balance in Power Electronic Based Power entities: Concept, Modeling, and Analysis," IEEE Transactions on Smart Grid Year:2018, Volume: PP, Issue: 99 Pages: 1 – 1.

